

TDJS series

Bulkhead units TDJS 35,
TDJS 50 and TDJS 70



Because the evaporator is external, there is no loss of load capacity. The low unit weight means payloads can be maximized and vehicle performance is unaffected.

Over the road, the vehicle engine drives the refrigeration unit by means of V-belts and a magnetic clutch. This system is exceptionally quiet. The highly efficient 3D scroll compressor ensures maximum cooling capacity even at idle speeds. Continuous run, maintenance-free evaporator fans are fully enclosed and provide highly reliable and efficient operation. Electric stand-by can be provided with a quiet, lightweight kit installed under the floor.

Attractive external styling delivers a highly durable, robust unit with excellent service access.

A user-friendly in-cab remote control means the operator can operate and monitor the system from the safety of the cab via a digital display.

Unit components are carefully designed and rigorously tested by MITSUBISHI to guarantee a dependable, efficient and high-performing refrigeration system.

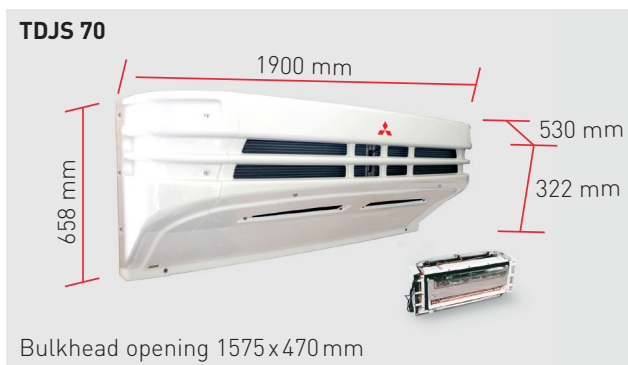

MOVE THE WORLD FORWARD

MITSUBISHI
HEAVY
INDUSTRIES
GROUP



Remote control



Multi-function valve

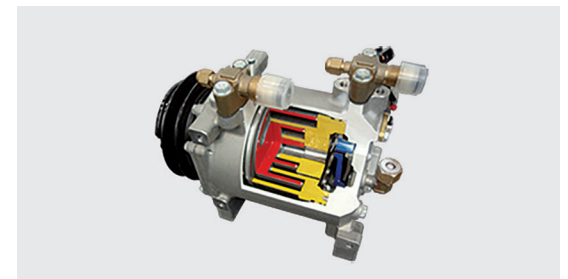

3D scroll compressor



Stand-by kit for stand-by-refrigeration



Benefits:

- > Direct drive for low noise and high performance
- > External evaporator enables 100% load capacity
- > Stand-by refrigeration option for low noise operation when parked
- > Multi-function valve for efficient performance and maximised cooling
- > MITSUBISHI 3D scroll compressor for high cooling capacity at low engine speeds
- > Multi-temperature version available for flexibility in delivery operations
- > In-cab remote control is user-friendly for error-free operation

Cooling capacity (ATP tested)	TDJS 35		TDJS 50		TDJS 70	
	CS 55 Compressor	CS 90 Compressor	CS 90 Compressor	CS 150 Compressor	CS 90 Compressor	CS 150 Compressor
to 0 °C	2939 watt	4135 watt	4760 watt	5421 watt	6040 watt	6990 watt
to -20 °C	1655 watt	2225 watt	2448 watt	3077 watt	3424 watt	4270 watt
Refrigerant	R452A	R452A	R452A	R452A	R452A	R452A
Air flow	1280 m³/h	1280 m³/h	1255 m³/h	1255 m³/h	1658 m³/h	1658 m³/h
Weight	78 kg ** drive refrigeration only (without electric motor) 152 kg ** drive and auxiliary cooling (with electric motor)		82 kg ** drive refrigeration only (without electric motor) 156 kg ** drive and auxiliary cooling (with electric motor)		97 kg ** drive refrigeration only (without electric motor) 237 kg ** drive and auxiliary cooling (with electric motor)	

** Weights include compressor, accessories and piping



Low maintenance

- > Evaporator fans are maintenance-free
- > Serviceable system components are easy to access



Multi-function valve

- > This patented valve enables over 75 % of the cooling capacity to be available even at low engine speeds typically experience in heavy traffic. This makes the system the perfect choice for urban distribution. In addition, start-up is easier and refrigeration performance is optimized.



Options

- > Stand-by refrigeration kit: The underfloor design locates the weight-reduced components low down and behind the front axle to maintain a low centre of gravity and optimal vehicle handling. The fully enclosed electrical unit features extremely quiet operation.



Compressor

- > An extremely compact and lightweight 3D scroll compressor which provides impressive cooling capacity even when the vehicle engine is idling in urban traffic.